

ABSTRACT

In Today's world Power energy efficient monitoring system is most important. Power electronics based Power energy efficient monitoring system used here The PEEMS includes batteries and a digitally controlled single-phase voltage source inverter (VSI), which can be controlled as a current source or a voltage source depending on the status of the ac grid and the user's preference.

The PEEMS guarantees that the critical loads are powered when the ac grid fails; in which case, the VSI is controlled as a voltage source. It also accomplishes peak power control by supplying battery power to the local loads while they are powered by the ac grid if the loads get large. The electricity cost savings done by peak shaving are estimated. We are using microcontroller based power efficiency circuit that can be controller power and show the windows screen power unit and total load how much power using day to day.

A RMS value and current transformer using and average value count to load that is simple way to show the power. Atmega328 circuit and Mosfet-IRZ-44 and 100k resistor load circuit and 16x2 lcd screen. 16Mhz frequency of power.

In order to provide power to critical loads when the ac grid fails, the EMS detects grid failure and acts as a voltage source for the critical loads. In this mode of operation, The disturbance in the voltage waveform is noticeable when the EMS reconnects the ac grid to the loads as. There is also an inrush current into the diode rectifier because the dc voltage of the rectifier had sagged some during islanding mode. Note that the ac voltage produced by the EMS during the islanding mode is slightly smaller (about 7%) than the ac grid voltage.

I. INTRODUCTION

This thesis presents the design and implementation of designed to reduce the power loss in industries by power factor Energy savings and energy efficiency have become top priorities all around the world, stimulated by the Kyoto protocol and other pressing needs to reduce fossil fuel consumption [1]. Additionally, energy security is a necessity for many installations such as military bases and health care facilities where reducing energy consumption must be accomplished while keeping critical electrical loads serviced at all times. In this paper, A Power-electronics-based energy management system (EMS) is presented to accomplish peak power control in a single-phase power system while guaranteeing continuous service to critical loads at the same time. Peak power control, also known as peak shaving [2], is a method used to reduce the electricity charges for users with time of use (TOU) contracts and those who pay for the demand charges [1]. The power system does not need to be a micro-grid, meaning that distributed generation (DG) does not need to be part of the power system [4].

Micro controller its using this device is show the power efficiency and total load and input power and output power how much energies using per day unit a factor that is very easy to meter reading and tally day to show in device.

Active power and reactive power control to voltage and current and power factor each Electric device that can use at home and other site

At Atmega328 controller can b calculate to the all over load and power efficiency to and power factor each electric device .Mosfet IRZ-44 is using frequency changing mode to the circuit at note to frequency change over the load and peak value of current . Peak shaving is achieved by controlling the RMS current in the load, which is related to the source current. A threshold is set for the load current, such that when the load RMS current

exceeds this threshold; the EMS supplies some of the load current. This keeps the peak current drawn from the ac grid below a set limit. In the laboratory experiments presented here, the threshold for the load current is such that the peak shaving feature turns ON when the load current is greater than 2.2 Arms and turns OFF when the load current is below 2.1 Arms

The PEEMS turns ON to charge the battery at $t=0$ sin. as demonstrated by the PEEMS current Items being 180° out of phase with respect to the ac voltage. Only linear loads are used for this experiment, because the diode rectifier load is disabled. The battery charging mode of operation is allowed because the load is light, so the EMS does not need to provide an additional current for peak shaving.

The reactive power and by which the power factor value is increased and the system efficiency is also increased. useful for the industry and the commercial purpose because they are use heavy or high electricity consumption machine by which they also requirement of more power comparison than of others by which not enough power supply in the rural areas at all time so they feel difficulties but by the use of this project we reduced the power by mean of increase the value of power factor by use of capacitor in series.

II. METHODOLOGY

The power efficiency increase factor to the system design and apply the method and power consumption condition to Power saver is a convenience and necessary tool for consumers whose are used high load in industries and commercial purpose electricity is used the power d is monitor.

$$I = \frac{V}{R + R_L}$$

The voltage of this generator is given by $V = \alpha \Delta T$. Where, α is Seebeck coefficient and ΔT is the temperature difference between hot and cold junction.

Let R is the internal resistance of the **thermoelectric power generator** then the current flowing through the

external resistance R_L is given by Substitute the value of voltage in above equation we get current,

$$I = \frac{\alpha \Delta T}{R + R_L}$$

We know that power flow to external load is given by, $P_L = I^2 R_L$ Substitute the value of I

$$\text{Power, } P_L = \left(\frac{\alpha \Delta T}{R + R_L} \right)^2 R_L$$

This power will be maximum when $R = R_L$ So, maximum power is given by

$$P_{max} = \frac{(\alpha \Delta T)^2}{4R}$$

In Seebeck Power Generation the term (α^2 / R) is called figure of merit. For power to be maximum ΔT and (α^2 / R) should have large value or we can say internal resistance should be low and this can be done by decreasing the length and increasing the diameter. ΔT can be increased by increasing the temperature difference between heat source and heat sink.



Efficiency of Power Generator



The efficiency of thermoelectric power generator is defined as the ratio of power developed, P_L across load resistance, R_L to the heat flow, Q from the source

$$\begin{aligned} \text{Instantaneous power, } P &= V(t)I(t) = I_m \sin(\omega t + \frac{\pi}{2}) V_m \cos \omega t \\ &= I_m V_m \cos \omega t \sin \omega t = \frac{1}{2} I_m V_m \sin 2\omega t \end{aligned}$$

Power through capacitor consists of only fluctuating term and the value of power for full cycle is zero.

III. WORKING AND PRINCIPAL

Critical loads are those loads that must be powered at all times because they are critical to the mission [5]. Noncritical loads are connected in parallel to VAC, however, they can be shed when necessary using a thyristor switch. This increases the control of the power that can be directed to the critical loads when necessary. The ac grid can also be disconnected from if needed to island the operation of the PEEMS [2]. Typically islanding mode occurs when the ac grid fails. In this mode of operation, power to critical loads is guaranteed by drawing energy from the efficiency pack [5].

In project of power saver we use the Microcontroller Atmega328. A microcontroller (sometimes abbreviated μC , uC or MUC) is a small computer on a single integrated circuit containing a processor core, memory, and programmable input/output peripherals. Program memory in the form of Ferroelectric RAM, NOR flash or OTP ROM is also often included on chip, as well as a typically small amount of RAM. Microcontrollers are designed for embedded applications, in contrast to the microprocessors used in personal computers or other general purpose applications. Firstly we give 230v AC power supply to the transformer. Here we are using 12V,1Amp step down transformer that convert 230v AC into 12v AC. From the output of the x-mer, 3 lines i.e. R,Y and B goes on rectifier circuit (Signal conditioning circuit). Each line having 2 wires, one is phase and another is neutral. Diodes are connected in H pattern. Here we are using 1N4007 diode. It work as a rectifier that convert 12v AC into 12v DC. Capacitors are used in power supplies for smooth the output of a rectifier circuit. Here we are using three 7805 voltage regulator IC'S that fixed the voltage at 5volt. Register having 1k value and LED'S are also connected together in series for fault indication. Now 3 phase wires from this board goes to LCD board. Where these 3 wires are connected from three pin connector. This LCD board need an external power supply to operate this board, so we connect 9v battery from it. Here we used 16x2 LCD DISPLAY and ATMEGA 328 microcontroller which is 28 pin. LCD and Microcontroller are interfaced together. Microcontroller's first pin is reset. It's second pin connect. Microcontroller's 4th pin connect to LCD's 4th pin i.e. register select. It's 5th pin connect to LCD's 6th pin i.e. enable. It's 7th pin connect to 5v supply. 8th pin of microcontroller connect to ground. 9th and 10th pin of microcontroller connect to crystal oscillator and ceramic capacitor. where crystal oscillator provides clock frequency and ceramic capacitor used for noise elimination. 11th, 12th and 13th pin of microcontroller connect to three phases i.e. R,Y & B. 14th, 15th, 16th & 17th pin of microcontroller connect to LCD's 14th, 13, 12th & 11th pin simultaneously these are data lines. 18th and 19th pin of microcontroller are open. 20th & 21st pin connect to VCC i.e. 5v. 22nd pin goes to ground & 23rd-28th pin are open. When system works properly LCD get initialized and display welcome message on it. If fault occurs in any one of the line, it indicates on LCD DISPLAY in the form of x-mer line1 fault, "X-mer" line2 fault or X-mer line3 fault with longitude and latitude. This current sensor LM 1172 connect inside of the x-mer. It is also connect to LCD board with 2 pin connector. Microcontroller sends high signal to relay driver IC whenever power factors falls less than 0.9. BC-547 turn on relays which in return connects capacitor banks with the load. First of all the phase difference between voltage and current waveforms are measured and then power factor is calculated. In case of low power factor capacitors are added to improve it.

Hardware Block diagram Design

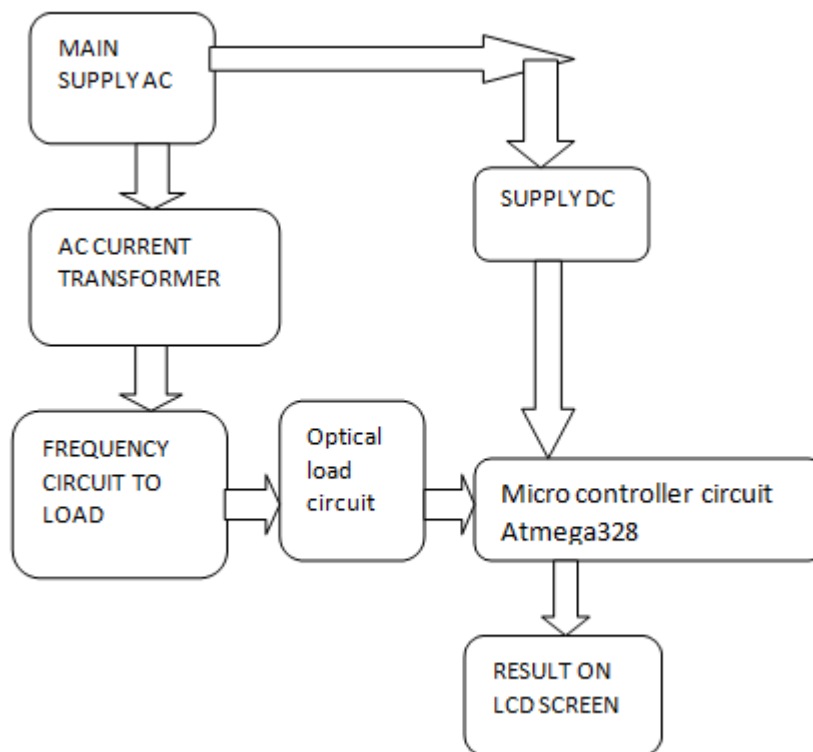

IV. CIRCUIT DESIGN

PEEMS LOAD CIRCUIT

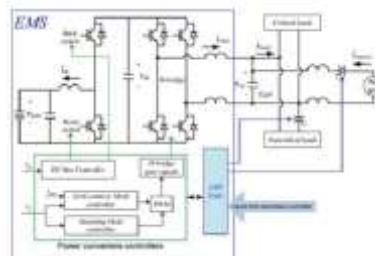

The PEEMS functionality is demonstrated in this paper by experimental validation with a laboratory prototype. The following scenarios are discussed:

1. Peak shaving by tapping the energy storage system during high power demand
2. Islanding or stand-alone mode of operation when the main ac grid is no longer available;
3. AC current mode.

In power electronics based energy management system when ac grid is available, at that time critical load are heavy load, low power load will calculate power system.

4.1 Circuit monitor for power efficient

The estimates break down energy consumption by "end use". End uses reported by Home Energy efficiency include heating, cooling, water heating, major appliances, small appliances, and lighting.

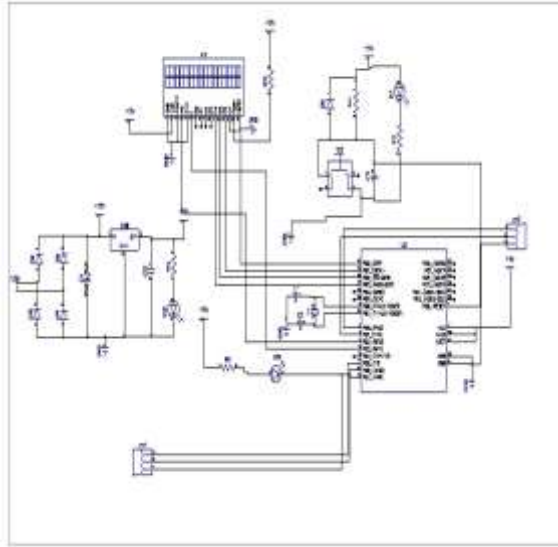

V. EXPERIMENTAL RESULTS

Residential and commercial TOU electricity rates include different rates at different time of the day and also demand charges. These rates are devised by the power companies to encourage customer to shift their loads away from the peak demand times and in general reduce their peak power consumption. By reducing the peak power consumption results in significant cost savings. Peak shaving is a known technique used to achieve this objective by use of stored energy. Electrical energy is stored during the times when electricity cost is lowest (typically at night) and used during the times when electricity cost is highest, in order to reduce the overall electricity charges.

User show the load calculation power and how much unit to device power consumption unit.

For more details on how pic microcontroller measures power factor and done power factor measurement calculation, check following article. I have explained working on power factor measurement project in this article. microcontroller calculate power factor and take necessary actions based on power factor. Relay driver ic lm A1172 is connected with microcontroller and which is used to drive relays. Microcontroller sends high signal to relay driver IC whenever power factors falls less than 0.9. BC-547 turn on relays which in return connects capacitor banks with the load. First of all the phase difference between voltage and current waveforms are measured and then power factor is calculated. In case of low power factor capacitors are added to improve it.

An "active power factor corrector" (active PFC) is a power electronic system that controls the amount of power drawn by a load in order to obtain a power factor as close as possible to unity. In most applications, the active PFC controls the input current of the load so that the current waveform is proportional to the mains voltage waveform (a sine wave). The purpose of making the power factor as close to unity (1) as possible is to make the load circuitry that is power factor corrected appear purely resistive (apparent power equal to real power). In this case, the voltage and current are in phase and the reactive power consumption is zero. This enables the most efficient delivery of electrical power from the power company to the consumer. Some types of active PFC are: Boost, Buck and Buck-boost. Active power factor correctors can be single-stage or multi-stage. Active PFC is the most effective and can produce a PFC of 0.99 (99%).upon our power factor ratio.

In most commercial and industrial facilities, a majority of the electrical equipment acts as a resistor or an inductor. Resistive loads include incandescent lights, baseboard heaters and cooking ovens. Inductive loads include fluorescent lights, AC induction motors, arc welders and transformers.

Typical power factor values for some inductive loads

Practical implement prototype Project



The all system design first PCB design by software, and transformer design AutoCAD connected to a wire and coil turns 1000 and component soldering by PCB check the hardware of the system testing LCD display show the location and Fault and fault circuit Also design by PCB and connect to Line phase and current module also connect to this system



Operation PCB

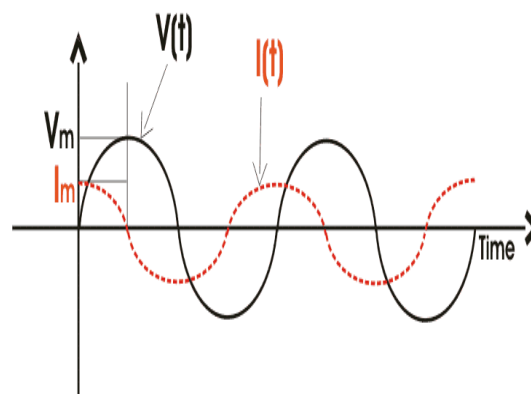

Figure(h)

Output voltage and current waveform

Advantages of the system

1. This system design is very useful for electric power unit maintenance.
2. This System protection for very have loss for transformer
3. In system can b control over load problem.
4. Power distribution unit to easy way.
5. The system design very low cost.

VI. CONCLUSION

By using this technique of energy management system critical load are powered even if AC grid fails. The control system designed to perform the experimental implementation of typical scenarios is presented in this .the PEEMS supports critical loads when the ac grid becomes unavailable and how the connection to the ac grid is restored by the PEEMS when the ac grid becomes available again. Additionally, the PEEMS can have other advantageous tasks such as peak shaving. Experimental measurements with linear and nonlinear loads demonstrate how the PEEMS, controlled in current mode, provides some of the power to the loads to accomplish peak shaving, thus reducing the cost of electricity. To resolution to over load of power.

VII. SCOPE FOR FEATURE WORK

A power saver monitor at a module can be connect to this system for receiving and storing capacitance parameters information periodically about all the distribution power of transformers utility in a database application. This database will be a useful source of information on the utility transformers. The utility in monitoring the operational work of their distribution transformers and identify faults before at characteristics failures thus resulting in significant very cost saving fast working system reliability.

The automatic power factor correction using capacitive load banks is very efficient as it reduces the cost by decreasing the power drawn from the supply. Install conditions as harmonic filters to avoid harmonic resonance problems and excessive voltage distortion levels.

REFERENCES

- [1] G. M. Masters, Renewable and Efficient Electric Power Systems. New York, NY, USA: Wiley 2004.
- [2] IEEE Standard for Interconnecting Distributed Resources with Electric Power Systems, IEEE Std. 1547, 2003.
- [3] J. Rocabert, A. Luna, F. Blaabjerg, and P. Rodriguez, "Control of power converters in AC micro-grids," IEEE Trans. Power Electron., vol. 27, no. 11, pp. 4734–4749, Nov. 2012.
- [4] S. Vazquez, S. M. Lukic, E. Galvan, L. G. Franquelo, and J. M. Carrasco, "Energy storage systems for transport and grid applications," IEEE Trans. Ind. Electron., vol. 57, no. 12, pp. 3881–3895, Dec. 2010.
- [5] Power electronics based energy management system, Giovanna Oriti, Senior Member, IEEE, Alexander L. Julian, Member, IEEE, Nathan J. Peck 833 Dyer Road, Spanagel 437, Monterey, CA, 93943 - USA
- [6] http://www.xilinx.com/support/sw_manuals/sysgen_gs.pdf.
- [7] J. Tiemann and N. Y. Schenectady, "Apparatus for Converting Vibratory Motion to Electrical Energy" U.S. Patent 5578877, November 1996.
- [8] Williams C.B. and Yates R.B., "Analysis of a microelectric generator for Microsystems". Source: Sensors and Actuators A: Physical,. Vol52, no. 1, pp. 8-11, March 1996 .
- [9] J. R. Amirtharajah and A. P. Chandrakasan, "Self-powered signal processing using vibration-based power generation," IEEE Journal of Solid-State Circuits, vol. 33, pp.687 – 695, May 1998
- [10] Scott Meninger, Jose Oscar Mur-Miranda, Rajeevan Amirtharajah, Anantha P. Chandrakasan, and Jeffrey H. Lang, "Vibration-to-Electric Energy Conversion", IEEE Transactions on Very Large Scale Integration (VLSI) Systems, VOL. 9, NO. 1, pp.64-76, February 2001.
- [11] P. D. Mitcheson, T. C. Green, E. E. Yeatman, and A. S. Holmes, "Architectures for Vibration-driven Micropower Generators", Journal of Microelectromechanical Systems, vol. 13, Issue 3, pp. 429-440, June 2004.
- [12] Chitta Ranjan Saha, Terence O'Donnell, Heiko Loder, Steve Beeby, and John Tudor, "Optimization of an Electromagnetic Energy Harvesting (2013).

CITE AN ARTICLE

Kumar, V., & Mehar, V. (2018). STUDY ON POWER ENERGY EFFICIENT MONITORING SYSTEM WITH LOAD. *INTERNATIONAL JOURNAL OF ENGINEERING SCIENCES & RESEARCH TECHNOLOGY*, 7(9), 114-120.